

STRYKER RIB LUX 380

The Stryker RIB LUX 330 is a luxury light weight deluxe tender with integrated rear seat, console, bow locker & EVA details.

SPECIFICATIONS

SIZE

- Overall Length 380cm or 12' 5"
- Inside Length 230cm or 7' 5"
- Overall Width 215cm or 7'
- Inside Width 107cm or 3' 5"
- Weight 245kg or 540lbs
- Tube Diameter 50cm or 1' 6"
- # of Air Chambers 3
- PVC Thickness 0.9mm

CAPACITY

- Max Load 692kg or 1526lbs
- Max # people 7
- Max Motor 50HP
- Max Motor Weight 157kg or 346 lbs
- Transom Height 20"
- Max Tube Pressure 3.6 psi

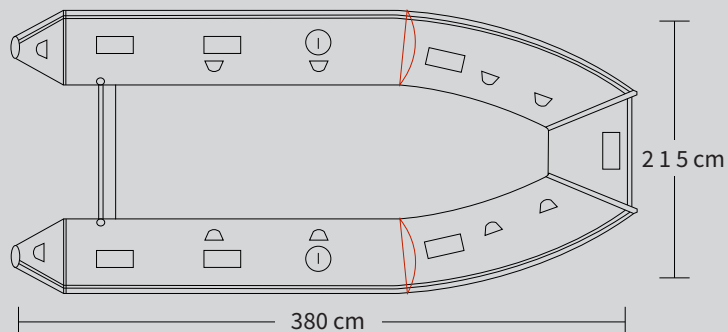



FEATURES

- Entirely Thermowelded Seams
- Integrated Transom Supports
- 3mm Aluminum hull
- 0.9mm Heytex PVC Tube
- Stryker Shield™ Keel Strake
- Stryker Shield™ Under Tubes
- Side Steps w/ EVA
- Anti Over-Inflation Safety Valve
- Reinforced Tube to Transom
- Fiberglass Step
- Exterior Water Redirecting Strake
- Handle @ Bow
- Tow Rope
- 2 Tow Rings on Aluminum Hull
- Bow Locker
- Removable Cushions
- One Way Scuppers & Threaded Drain Plug
- Carry Handles
- Fiberglass Console w/ Center Seat
- Engine Mounting Plate
- Built in fuel tank 30L
- Bow Step w/ Lights & Anchor Bolt

INCLUDED IN BOX

- Fiberglass console with front seat
- Electrical pack for boat & console --
- including bilge pump & port/starboard lights on bow
- boarding step, multifunction panel switches, power
- master switch, fuel gauge;
- Aluminum Oars
- Foot Pump
- Repair Kit
-
-
-