

STRYKER PRO 470

The Stryker PRO 470 inflatable boat comes with the added protection of 1.8mm wrapped with our Stryker Shield® under the entire bottom of the boat. There is no other comparable boat on the market today. We add a 20" transom for the ability to add a JET outboard for extreme shallow water use. Please note: this model requires a 20" prop motor. This is the perfect inflatable boat for a large group of adventure seekers paired with a 30HP long shaft (prop) outboard or a 35HP JET.

SPECIFICATIONS

SIZE

- | | |
|---------------------|-----------------|
| ○ Overall Length | 470cm or 15' 4" |
| ○ Inside Length | 320cm or 10' 5" |
| ○ Overall Width | 190cm or 6' 2" |
| ○ Inside Width | 90cm or 2' 10" |
| ○ Weight | 287 lbs |
| ○ Tube Diameter | 20" |
| ○ # of Air Chambers | 6 |
| ○ PVC Thickness | 1.8mm & .9mm |

CAPACITY

- | | |
|---------------------|-------------------|
| ○ Max Load | 1588kg or 3502lbs |
| ○ Max # people | 12 |
| ○ Max Motor | 60 HP |
| ○ Max Motor Weight | 119kg or 262 lbs |
| ○ Transom Height | 20" |
| ○ Max Tube Pressure | 3.6 psi |

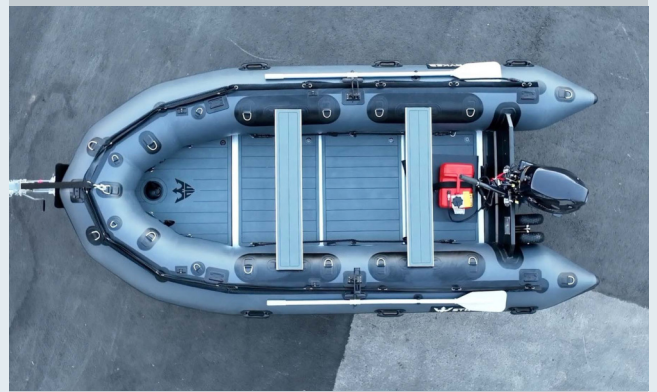
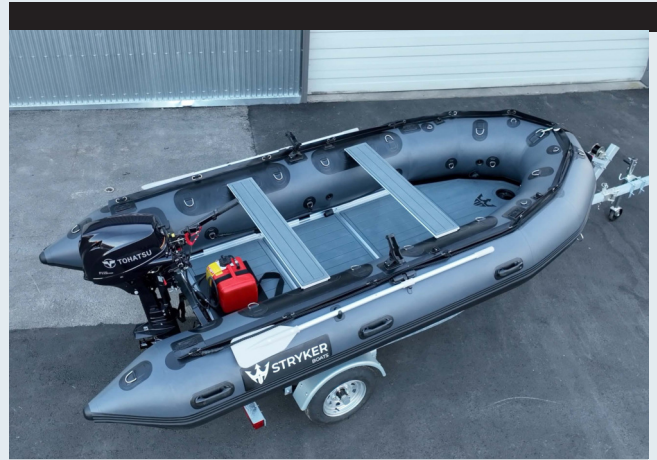
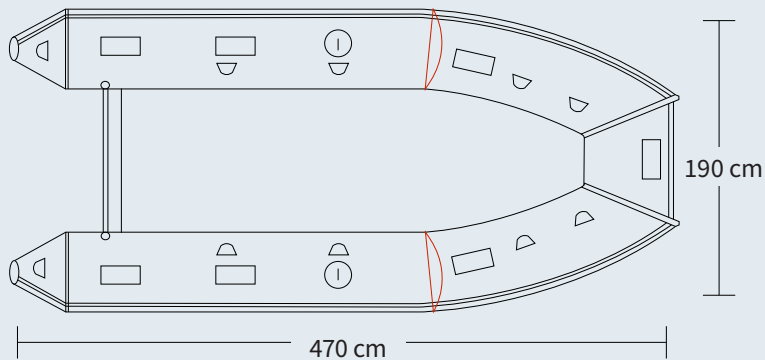

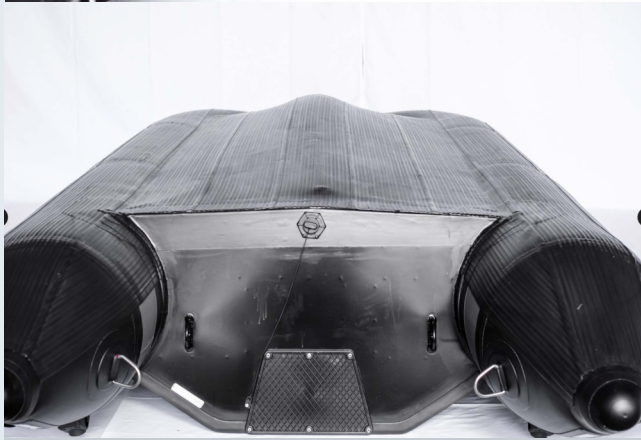

FEATURES

- Entirely Thermowelded Seams
- Aluminum Transom
- 1.8mm Underbelly
- 1.8mm Protective Seat Patches
- Full Stryker Shield™ Under Boat
- Pre-Installed EVA Mats
- 7 x Scotty Mount Pads
- Anti Over-Inflation Safety Valve
- Reinforced Tube to Transom
- Complete Peripheral Life Line
- Exterior Water Redirecting Strake
- D Handle @ Bow w/ Tow Rope
- D Rings Installed
- 2 Tow Rings
- Oar Locks
- Oar Holders
- Drain Valve
- 6 Carry Handles
- 10 Interior D Rings
- Integrated Engine Mount Plate
- Gas Tank Pad & Belt
- Bow & Sunshade Bimini Mounts Installed

INCLUDED IN BOX

- 2 x Aluminum Bench Seat
- 2 x Scotty Baitcaster Rod Holders
- Bimini
- Bow Bag
- Seat Bag
- Aluminum Oars
- Boat Bag
- Floor Bag
- Essentials Bag
- Foot Pump
- Repair Kit



1.844.322.BOAT (2628) • STRYKERBOATS.COM