

STRYKER HD 380

The Stryker HD 380 offers all the standard features of the Stryker LX line with the addition of 5 air chambers, 2 extra Scotty Bases® (7 in total), 1.8mm material for hull and additional seating protection. A bimini top and 2 Scotty Baitcaster rod holders are included. This inflatable boat is available in black or green.

SPECIFICATIONS

SIZE

- Overall Length 380cm or 12' 5"
- Inside Length 260cm or 8' 5"
- Overall Width 172cm or 5' 6"
- Inside Width 80cm or 2' 6"
- Weight 241 lbs
- Tube Diameter 46cm or 1' 5"
- # of Air Chambers 6
- PVC Thickness 1.8mm & .9mm

CAPACITY

- Max Load 1025kg or 2259lbs
- Max # people 8
- Max Motor 30 HP
- Max Motor Weight 119kg or 262 lbs
- Transom Height 15"
- Max Tube Pressure 3.6 psi

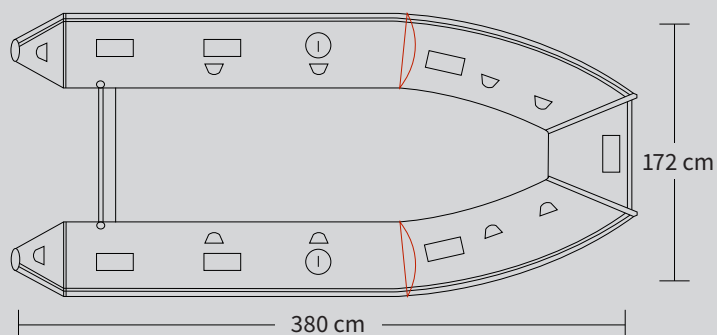



FEATURES

- Entirely Thermowelded Seams
- Aluminum Transom
- 1.8mm Underbelly
- 1.8mm Protective Seat Patches
- Stryker Shield™ Keel Strake
- Stryker Shield™ Under Tubes
- 7 x Scotty Mount Pads
- Anti Over-Inflation Safety Valve
- Reinforced Tube to Transom
- Complete Peripheral Life Line
- Exterior Water Redirecting Strake
- D Handle @ Bow w/ Tow Rope
- D Rings Installed
- 2 Tow Rings
- Oar Locks
- Oar Holders
- One Way Drain Valve
- 6 Carry Handles
- 10 Interior D Rings
- Aluminum Engine Mounting Plate
- Gas Tank Pad & Belt
- Bow & Sunshade Bimini Mounts Installed

INCLUDED IN BOX

- 2 x Aluminum Bench Seat
- 2 x Scotty Baitcaster Rod Holders
- Bimini
- Bow Bag
- Seat Bag
- Aluminum Oars
- Boat Bag
- Floor Bag
- Essentials Bag
- Foot Pump
- Repair Kit